

Product Description

Semitoool Spin Rinsers Dryer

800 Series ST

The Spin Rinsers/Dryer System, the world standard for high-performance cleaning, rinsing, and drying.

The overall concept of the Semitoool SRD is extremely simple. A single cassette of wafers is placed in a stainless steel rotor. The wafers are centered just off the axis of rotation, and rotated at high rpms so that centrifugal force will "lock" the wafers in place to prevent tumbling of the wafers and subsequent particle generation.

A spray manifold located at the 1:00 position in the process chamber sprays deionized (DI) water across the wafer surface at a rate of 1.5 to 2.0 gallons per minute at about 30 psi to remove loosely adhered particles, ionic, and water soluble contaminants.

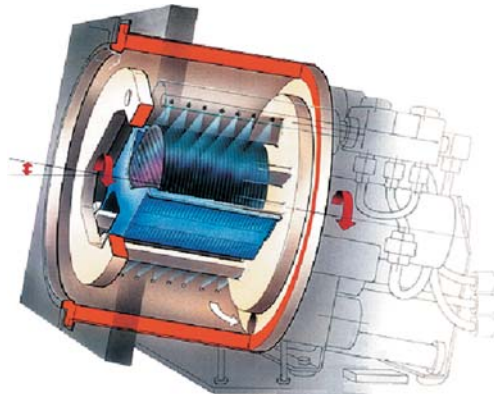

Rinsing is done either for a programmed period of time, or is controlled by a resistivity monitor. The resistivity monitor, located in the SRD drain box, can override the timer and requires a certain resistivity level before advancing to the next step. At the conclusion of the rinse step, the rotor is accelerated while the rinse manifold is purged with N₂. Next, heated N₂ is brought in through a dedicated drying manifold at about 30 psi for a programmed period of time. The rpm is then reduced to minimize turbulence and heated N₂ continues to be blown into the chamber until the wafers and carrier are suitably dried.

"ST" Models come standard with analog controllers, brushed motors and 4-bolt rotors.

SRD ST Model						
Model	Bowl Opening Diameter		Substrate Maximum			
			Diameter		Square	
840ST	8"	200mm	4"	100mm	4"	100mm
860ST	9.78"	250mm	5"	130mm	5"	130mm
870ST	11.5"	290mm	6"	150mm	6"	150mm
880ST	12"	300mm	* 8"	200mm	7"	180mm
8300ST	15"	380mm	9"	230mm	8.75"	220mm

* Requires use of low profile cassette



800 Series Stacker

Available Options At Additional Cost

- Resistivity Monitor w/probe (ST-RM-2)
- Anti Static with N₂ purge (CY-20)
- DI Water Recirculation (WR-20B)
- Emergency Power Off (EPO)
- Flaretek™ Fittings/Manifold (FLRTK)
- Mechanical Door Lock (DL-20)

Supply/Electrical Connections

Electrical

- USA: 120 VAC 60 Hz, 15 Amps
- Japan: 100 VAC 50 Hz, 18 Amps
- Europe: 240 VAC 50 Hz, 13 Amps

Supply

N₂ - 3/8" o.d. tubing at 4-6 cfm, (8300 - 1/2" o.d.)
 30-35 psig during SRD drying cycle.
 DI - 3/8" o.d. at 1.5 to 2.0 gpm maximum.
 (8300 - 3/4" o.d.) Facility pressure 25-30 psig.

Exhaust

An exhaust volumetric flow rate for a 1-1/2" line must be 7cfm (optional)

Drains

1-5/8" o.d./ i.d. 1-1/4" PVC tubing
 (8300 - 2-1/4" o.d. / i.d. 2-1/8")

